



Elefine

EF-DZJ10 AC Boom Barrier

User's Manual

Issue Date: 2021.08



Shenzhen Elefine Technology Co., Ltd.

www.elefinetech.com

Table

1) Production Outline	
2) Production Series	
3) Functions and Features	
4) Working Environment	
5) Machine Core Design	M 3
6) Protection Rules	Di 4
7) Installation, Adjustment and Use	Installation, A 5
Installation for Mechanism Part	5
Adjustment and Use of the Mechanism Part	6
Springs Selection, Installation and Adjustment	10
7.4) Installation and Connections of the Electric Part	13
7.5) Electricity Adjustment and Attentions	15
8) Common Malfunctions and Solutions	Com 16
9) Packing List	17
10) Service Items	18
2) Appendix	
1) Remote Control Code Instruction and Figure	18
2) Installation of the Infrared Photocell	19
3) Adjustment of the Limit Switch	20

1) Products outline

We adopt the most reliable barrier motor from an OEM barrier manufacturer in China, and with our own cabinet design and built to match our parking system devices. All production including assembly and testing are all locally conducted by technical team in our factory to ensure a premium quality level that can line up with our parking system products.

Production series

Model	Description	Max boom length (L ≤ meter)	Action time (second)	Boom height (meter)
EF-DZJ10S	Medium speed, straight	$L \leq 4 \text{ m}$	3	0.83
EF-DZJ10F	90° Folding boom	$L \leq 4 \text{ m}$	3	0.83

Attention: please read this instruction before installation!

Notice: The "Boom Height" means height from the boom holding point to the ground

3) Functions and Features

The humanized clutch device: In case of power off, unlock the clutch device and raise the boom manually. By the time the power is supplied, lock the clutch device to make it working normally again.

Special spring device: Both the compression spring and tension spring can be used in the machine. Using the compression spring can avoid accidents caused by the tension spring.

Three control buttons: for boom raising, falling and pausing.

3.4) Boom backtrack function: the boom will rise if it hits something when falling.

Infrared photocell design: for avoiding the crash when the boom falling, so as to prevent the vehicles from being pressed.

Both external and internal loop detectors are supported.

3.7) 'Open', 'Close' and 'Stop' controlling interfaces.

RS-485 communication serial interface (optional).

Traffic light signal connection device: red light for stop; green light for pass.

Remote control and wire control for selection.

4) Working environment

Machine core working temperature	-25 °C ~ +85°C
Electric cabinet working temperature	-20°C ~ +75°C
Rating voltage	220/110V±10%,50/60Hz
Rating power	100W
Relative humidity	≤ 90%
Remote control distance	≥ 30m
Net weight	65kg

5) Machine core

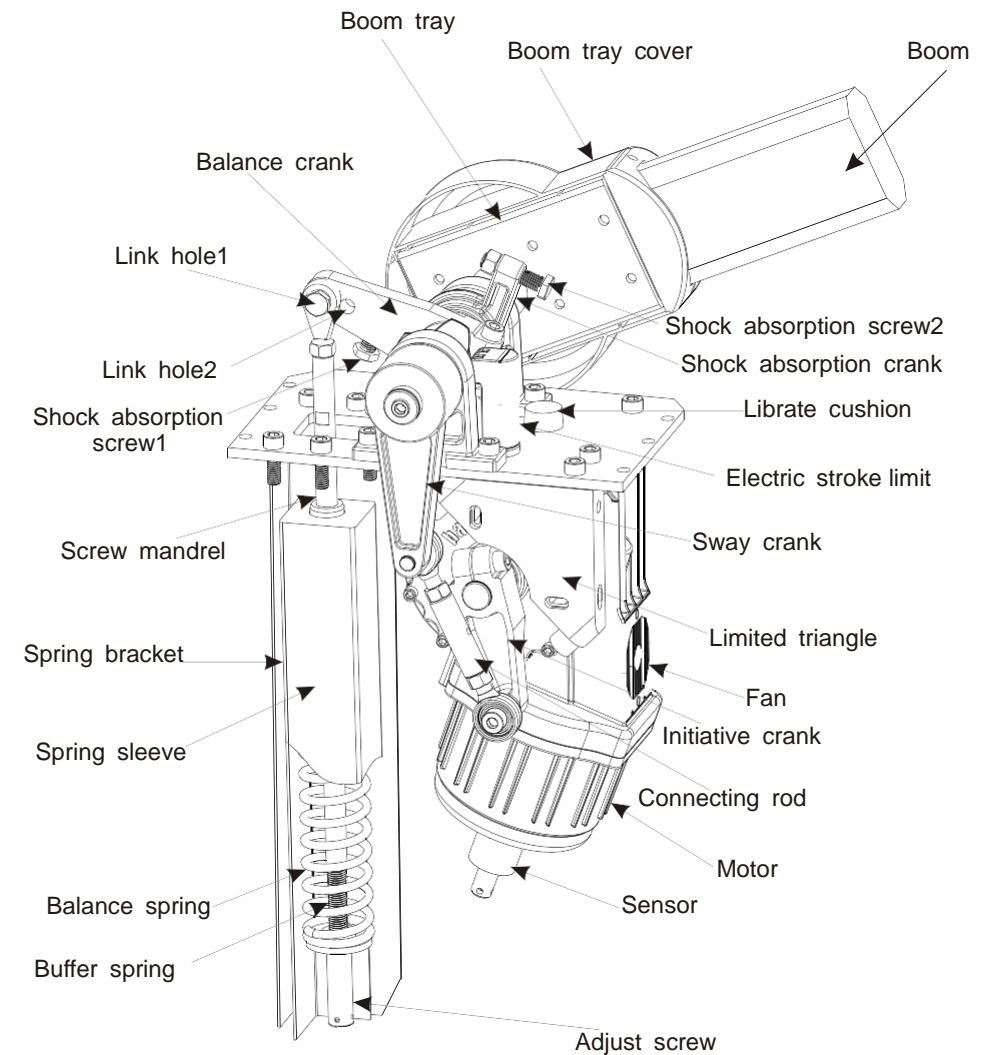

6) Direction rule

The right-side fixed barrier gate installation rule:

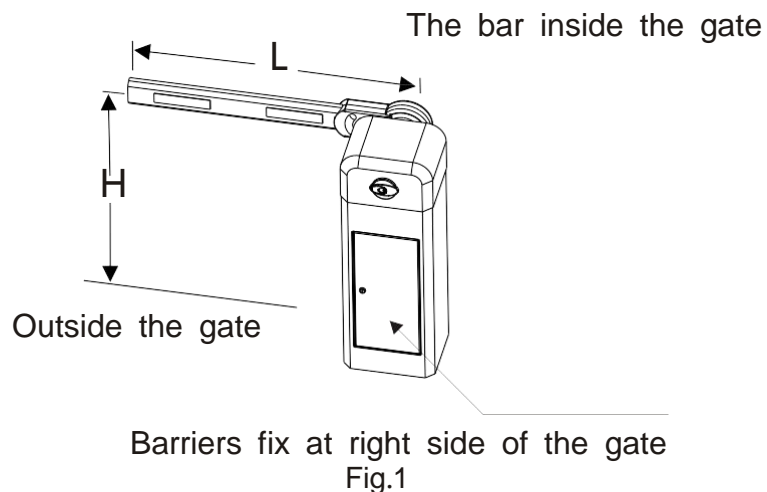

The barrier gate fix at the right hand side of the access

The left-side fixed barrier gate installation rule:

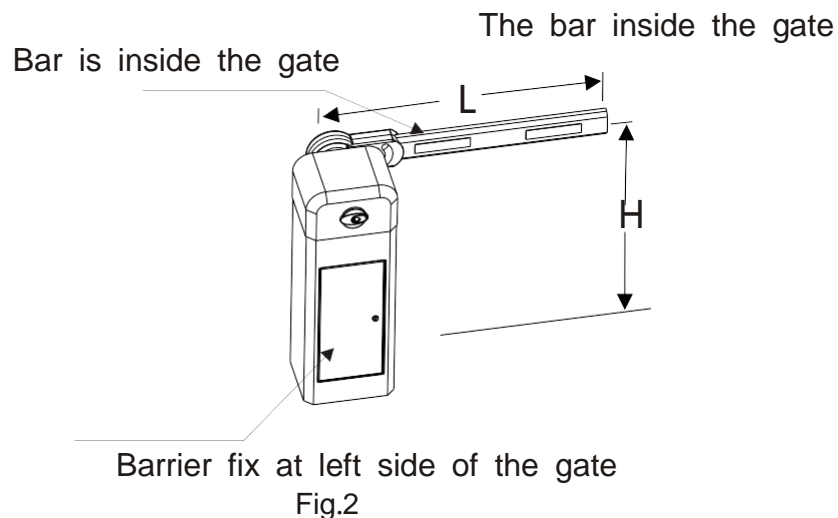

The barrier gate fix at the left hand side of the access

7) Installation, debugging and usage

Installation of mechanism part

7.1.1) Please select the right type of the barrier gates according to the specifications of the place. Fix the barrier gate case board with expansion bolts (refer to the fig.3)

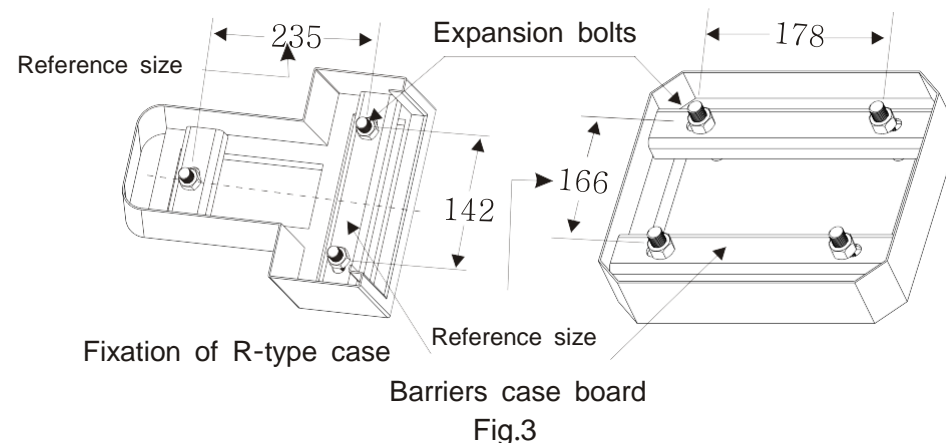

Fix the boom to the boom tray with the boom press board, then cover the boom capuche with the screws. After that, fix the cover of the boom to the splint and fasten them with four screws of 4x16, and slip the cover tap to the correspondent hole in the boom cover. Finally, fasten the cover tap with the cover by two 3x10 screws.

Unlock the clutch device with the clutch key clockwise. Move the boom to the horizontal and vertical position manually to make sure there is no obstruction. Then turn on the power (refer to the Fig.4)

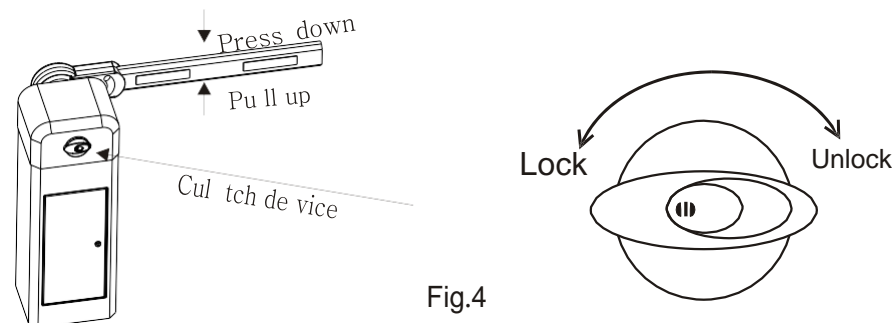

Debugging and use of the mechanism(cautions:turn off the power before setting)

Fig.5(Cautions: turn off the power before setting)

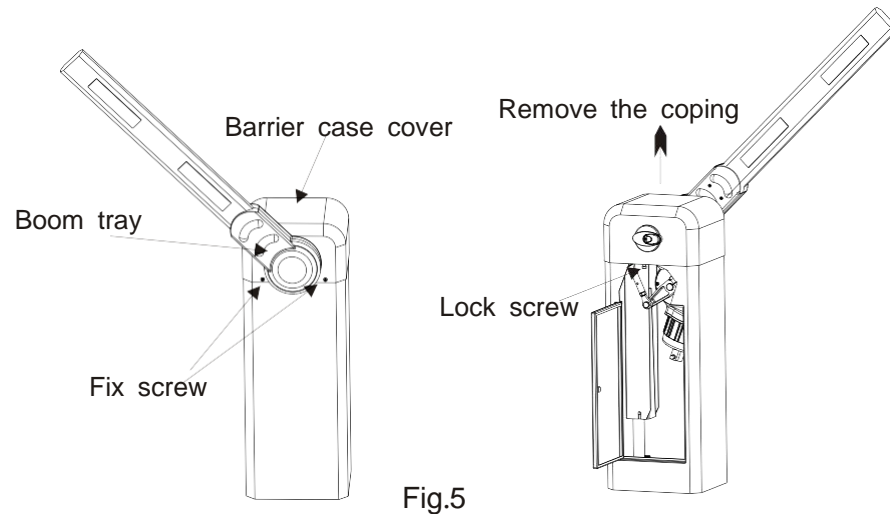

Fig.5

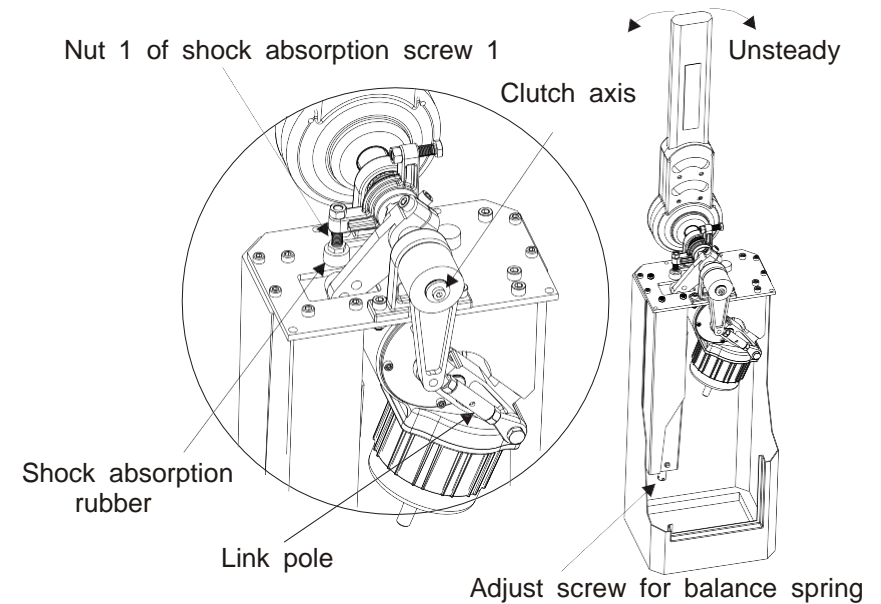

Fig.6

Fig.7

- (A) The barrier gate has been well set in our factory, but it can be further debugged if there is any problem in usage.
- (B) Dismantle the machine coping:(1)Remove the fixed screws which were fixed under the boom tray.(2)Open the machine door and loose the lock screws.(3)Take away the coping.(Refer to fig.5)
- (C) Methods to make the boom in the vertical position:
Fig.7(Attention:The clutch device should be locked in these methods.)
- (a) If the boom is not in the vertical position:(refer to fig.6)
- (a-1) raise up the boom to the vertical position, then loosen the Nut 1 of shock absorption screw 1 to diminish the press to the shock absorption rubber A.
If there is a gap between the screw A and rubber as the boom is in vertical position, please adjust it again until the press is just right.
- (a-2) Adjust locknuts in both sides of link pole until the boom is vertical. Then tighten up the locknuts again.
- (b) If the boom is unsteady in the horizontal position:(refer to fig.7)screw the adjusting screw of the balance spring clockwise to enhance the spring tension.
- (Attention: the spring tension could not be too hard.)

- (D) The best methods to adjust the boom(Attention:the clutch device should be unlocked in these methods), please try as follow:
- (a) Unlock the clutch device and erect the boom manually.
If the boom cannot keep standing or fall down easily, that means the balance spring is not tensional enough. In this case, move the boom to the vertical position and adjust the screw which is used to balance the spring.
- (b) Move the boom to 45 degrees manually.
If the boom is still easy to fall down, repeat the step the above step, until the boom does not fall down anymore and has the trend of moving upwards.
- (c) Change a new balance spring then readjust the boom again.
- (E) If the boom is vibrant too much when it backtracks in case of coming across any obstacle, please try as follow:(refer to fig.8)
- (E-a) Turn off the power, unlock the clutch device with the clutch key clockwise, and erect the boom to the vertical position manually. Adjust the adjusting screws of the balance spring anticlockwise to diminish the tension of the spring.

(E-b) Repeat Step(E-a).

(E-c) If the balance spring has been adjusted to the tension, the problem still could not be solved. Please hang the balance spring to link pole 2 instead of link pole 1.

If the problem still exists, please change a smaller line diameter spring and repeat the above steps.

(F) Methods to make the boom in the horizontal position:

(Attention: The clutch device should be locked in these

methods.) (F-a-1) If the boom is not at the exact horizontal position, please try

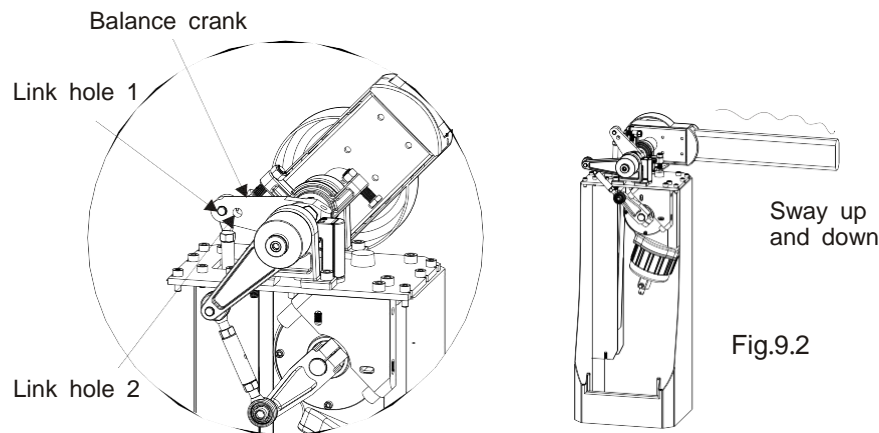
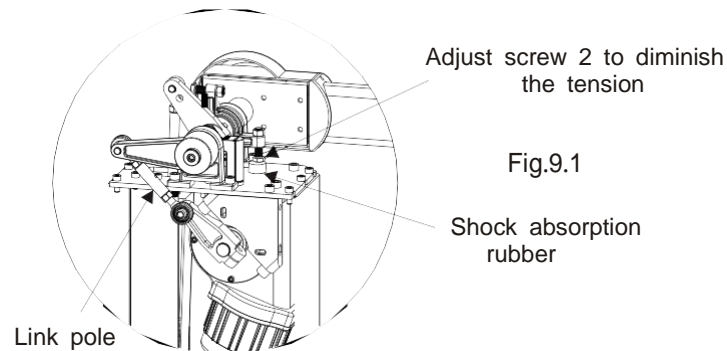

Fig.8

(F-a-1) Refer to Fig.9-1, fall down the arm, and then adjust the shock absorption screw 2 to make the boom in the horizontal position. If it doesn't work, try the next step.

(F-a-2) Loosen the locknuts on both sides of the link pole, rotate the link pole right or left to adjust the arm, then screw down the locknuts again when the boom is in the horizontal position.

(F-b) If the boom is vibrant as it falls down to the horizontal position.

(F-b-1) Refer to Fig.9-1, adjust the shock absorption screw B to diminish the press to the shock absorption rubber B(shock absorption cushion); if the adjusting is not satisfied, please try as follow.

(F-b-2) Unlock the clutch device, and rise up the boom to the vertical position manually. Rotate the adjusting screw for balance spring to enhance or diminish the tension.

(F-b-3) Lock up the clutch device and run the machine. If the problem still exists, retry the above steps.

(G) The method to lock up unlock the clutch device. The clutch can not be unlocked. Insert the clutch key and rotate it clockwise to unlock it, and the anticlockwise to lock it. If the clutch device could not been locked up or unlocked easily, please pull up or pull down the boom by hand lightly.(Refer to Fig.4)

Spring selection, installation, and adjustment

(A) Spring selection

A. Selection: Balance spring

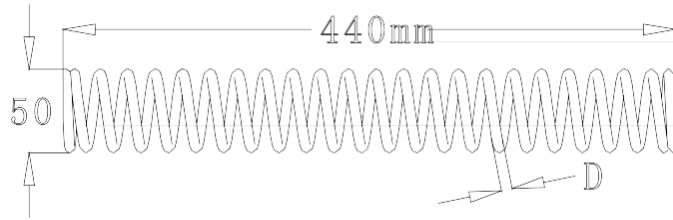

The parameter for selecting the balance spring

Num	The length of the arm (L=meter)	Line diameter/diameter of the spring (D=mm)	Link hole selection
1	$2.5 < L < 3.5$	D=4.5	Link hole 1
2	$3.5 \leq L \leq 4.0$	D=5.5	Link hole 2
3	$4.0 < L < 5.5$	D=6.5	Link hole 2
4	$5.5 \leq L \leq 6.0$	D=6.5	Link hole 1
5	$6.0 \leq L$	For special order	

Inbuilt spring:

Inbuilt spring: line diameter is 3.0 mm;

Length is 145 mm;

External diameter is 26 mm.

The length of the boom from 5.5 to 6 meters has additional instruction for inbuilt spring.

In order to make a safe and steady performance and to decrease the metal fatigue of the balance spring, 3 inbuilt springs covered with PVC pipe are inserted into the 6.5mm compressed balance spring and separated with rubber cushion.

- (B) Spring installation
- (B-a) Select a suitable spring together with the screw mandrel and insert them into the spring sleeve.
 - (B-b) Put the whole assembled sleeve into the spring bracket.
 - (B-c) Make the screw mandrel connected to the balance crank by link hole 1 or link hole 2.
 - (B-d) Install the gasket and the screw at the bottom of the screw thread pole.
 - (B-e) Spin the screw clockwise to adjust the press of the balance spring, so that it can balance the weight of the arm.
- (C) Spring replacement
- (C-a) Rise up the boom to the vertical position. If the power is off, unlock the clutch device, put the boom to the vertical position manually, and make sure the boom would not fall down.
 - (C-b) Spin the bottom adjusting nut anticlockwise to disassemble it and the baffle ring.
 - (C-c) Fall down the boom to the horizontal position manually, loosen the fixed screw and take out the screw mandrel from the spring sleeve.
 - (C-d) Loosen 4 setscrews to take off the spring sleeve for changing the new spring.(Refer to Fig.10)

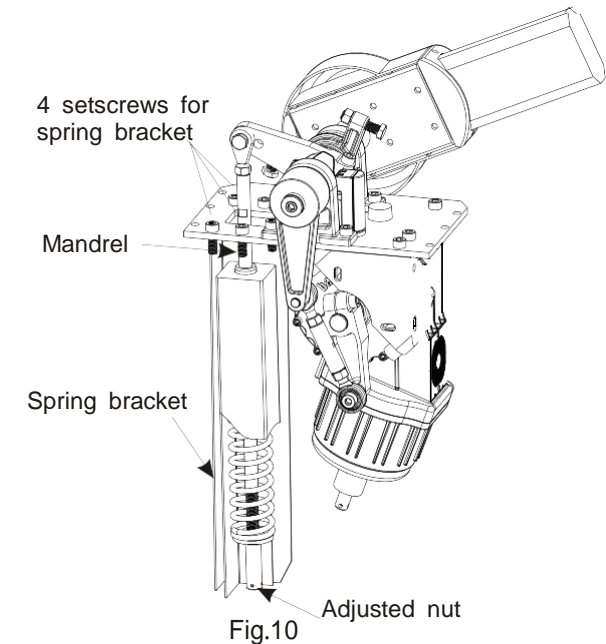

- (C-e) Insert the screw mandrel again and fix it to the selected link hole.
- (C-f) Rise up the boom to the vertical position again and make sure the boom will not fall down.
- (C-g) Install the adjusting nuts and the baffle ring in the lower part of the screw mandrel and adjust the press to the balance spring , so that it can balance the weight of the arm.

(D) Spring adjustment

The bottom screw can be screwed clockwise or anticlockwise to adjust the press to the balance spring.(Refer to Fig.11)

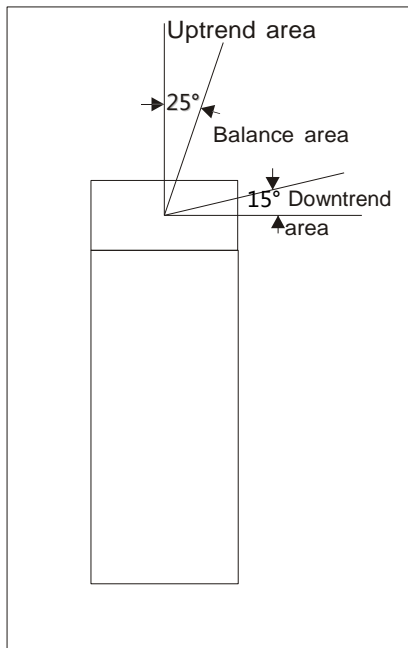

Fig.11

- (D-a) In the uptrend area, the boom will move upright because of the balance spring.
- (D-b) The boom can keep balance and motionless in any position of the balance area.
- (D-c) In the downtrend area, the boom will be fallen down to horizontal position because of the gravity.

Installation and connections of the electric part(refer to Fig.12)

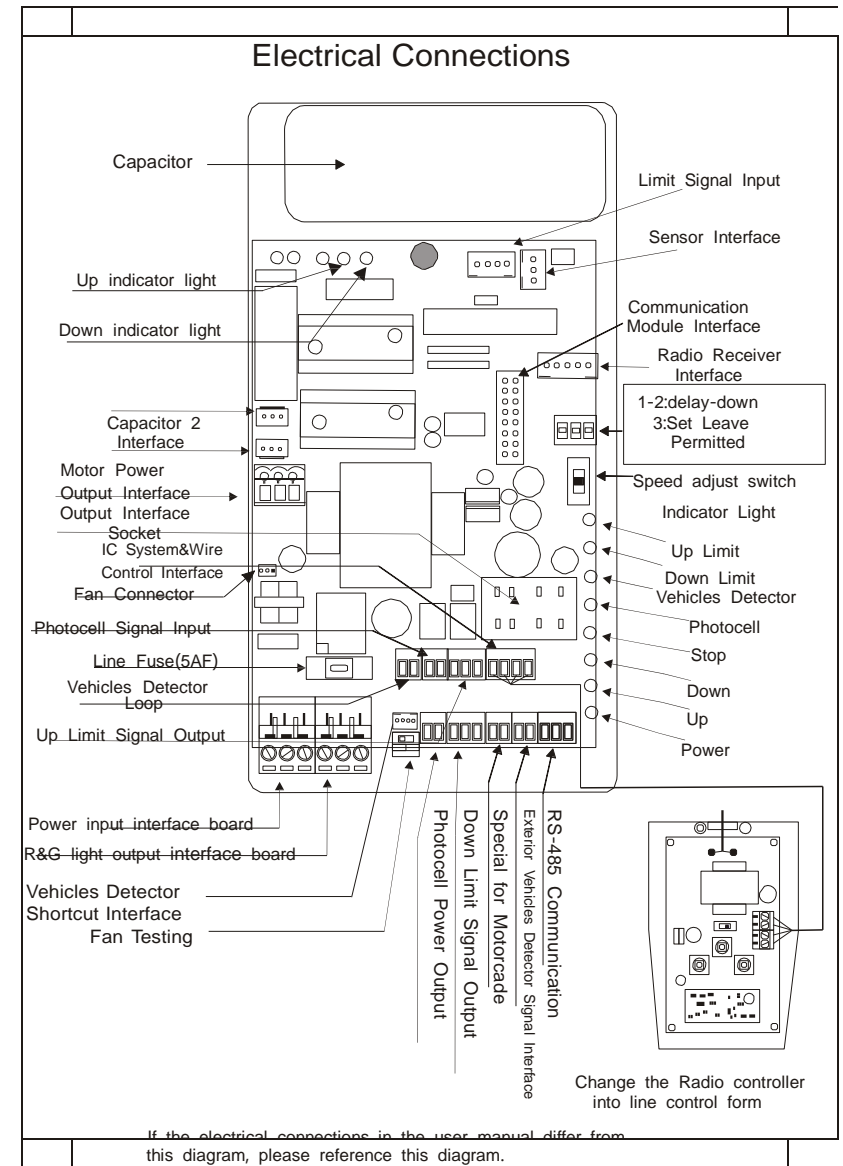

Fig.12

- (A) 220V(110V) power connection:
Remove wiring terminal cover and connect power wire to [Power input interface board].
- (B) Traffic light (R&G light) connection:
The traffic light connector provides 220v power. Connect the Red Light Wire, Green Light Wire and COM wires to the [R&G light output interface board] according to text indication printed on the board.
- (C) Photocell emitter and receiver connection:
To use photocell device, first connect photocell (emitter and receiver) to wiring terminal power output [Photocell power output], and then connect receiver signal wire to signal input [Photocell signal input] on wiring terminal board.
- (D) Loop detector terminal:
This controller can support both the internal and the external loop detector connections.
However, just one way can be chosen.
If external loop detector is selected, just connect the loop detector to 220V power, and connect the signal wire to the signal input terminal.
If the internal loop detector is selected, connect the internal loop detector to the socket on the circuit board directly and the signal wire to vehicles detector signal input terminal.
- (E) "COM","UP","DOWN","STOP" signal input terminal:
The input terminal can work as a switch. If choose the "UP", "DOWN","STOP" input terminal to connect to the "COM" by a wire, the main board will give the correlative reaction signal to the barrier gate arm.
The user can use this method for the IC system controlling or the circuitry controlling.(Note: the wire control is advised to be used in the guards' room)
- (F) "UP" and "DOWN" position limit switch:
This switch transmits the "UP" and "DOWN" command to boom by optical signal.(Notice: More details please refer to Fig.12)
- (G) RS485 serial communication terminal:
The main board supports the Rs485 serial communication to control the boom UP and DOWN. Please link the computer with Rs485 interface by the communication module.
The software please refer to the instruction in the disk.(Optional device)

- (H) Terminal special for motorcade:
If the users have installed the loop detector, and do not want the barrier boom fall down automatically when there are still some cars in line behind the passing car. Then please add an exterior circuit to this device. If the circuit is on, the loop detector will work; if the circuit is off, the loop detector will not work.

Electric part adjustment and attentions

- (A) Barrier gate controlling:
There are three buttons to control the barrier gate conveniently when the barrier gate sets well.
If the boom can not fall down or rise up to the right position, or rises up automatically after reaching the horizontal position, please check whether the abnormal situation is caused by loop detector or not.
If the abnormal situation mentioned above is not caused by loop detector, please check the "Gate Type Selection" setting.
(Note: the barrier gate speed has been fixed. And this "Gate Type Selection" is just for controller adjustment to keep its' working speed accord with the barrier gate speed.) The "Gate Type Selection" has been well set before leaving our factory, but user can adjust it if needed.
- (B) Boom backtrack function:
The boom will rise up if it comes across obstacles when falling. And it will stop if it hits something when rising.
- (C) Infrared photocell function:
If the infrared signal is cut off when the boom is falling, the boom will rise up automatically.
- (D) R&G light terminal:
The light will turn green only when the boom is at the vertical position. Red light is for other positions.
- (E) Loop detector terminal:
If the vehicles detector is installed correctly, the boom will automatically rise up when there is some press of the vehicle on the loop, and it will automatically fall after the vehicles leaves the loop.

8) Common malfunctions and solutions

- (1) Motor works but there is no reaction on the arm
 - a. Please check whether the clutch device is locked or not.
- (2) There is too much vibrant when the boom is rising or falling.
 - a. Please check whether the shock absorption rubber is broken or not, if yes, change a new one.
 - b. Please check whether the balance spring is overused and distorted. If yes, change a new one; or spin bottom adjust nut.
- (3) The boom could not rise up or fall down to the end.
 - a. When change a long boom to a short one, please readjust it.
 - b. The sensor dose not plug well, please check it.
 - c. The "Speed adjust switch" is wrong adjust, please readjust it.
- (4) The distance of the remote control decreases.
 - a. Check whether the charge capacity of the remote controller is enough or not.
- (5) There is no reaction when pressing the remote controller buttons.
 - a. Please check whether the power is supplied to the barrier gate or not.
 - b. Please check whether the fuse is burnt out or not.
 - c. Please check whether the code both in the remote controller and the control board are accordant or not.
- (6) There is no reaction on the motor when the user changes a control board.
 - a. Please check the capacitance is correctly fixed or not.
 - b. Please check the sensor is right inserted or not.

- (7) If the user changes a new control board and the boom is abnormal when rising and falling.
 - a. Please adjust the "Gate Type Selection"(Refer to the control board).

9) Packing list

Title	Specification	Qty	Note
Barrier Gate Core		1	Main part
Barrier Gate Boom	Straight boom/Fence boom/ Folding boom	1	According to your choice
Hexagonal Head Tap Bolt	M8x55mm	6	For fixing the boom
Boom Press Board		1	For fixing the boom
Self-tapping screw	ST4x16	1	For fixing the boom
Self-tapping screw	ST3x10	4	For fixing the boom
Supporting pole		1	For supporting the boom
Expansion Bolt	M16x150	4	For fixing the case
Hexagonal Inner Screw	M8x35	4	For fixing the case
Clutch Key		1	For clutch device
Case Key		2	For barrier gate case and cove locking
Balance Spring	According to length of the arm	1	For spare usage
Remote Emitter	Less than 30M is available	1	For remote controlling
Remote Controller	Less than 30M is available	2	For remote controlling
Instruction		1	For reference
Rs485 transition Interface		1	Optional part
Disc		1	Optional part
Communication Module		1	Optional part
Cover head		1	
Expansion nut	M8	4	For fixing the supporting pole

10) Service items

- (1) One year's free servicing is supplied(not including the arm);
- (2) Lifetime charged servicing is offered.
- (3) Technology servicing is supplied.

The following situations are charged for servicing(or changing):

- (1) Broken by wrong installation.
- (2) Broken by improper voltage.
- (3) The surfaces of the system destroyed by wrong installation or use.
- (4) Broken by natural disaster.
- (5) Overdue.
- (6) Servicing items out of our promises.

The upgrade and improvement of the product won't be notified if there is any.

The explaining authority of this product instruction and service article belongs to the production factory.

Appendix

1) Remote control code instruction and figure

If the remote control code does not match the one on the remote controller and the infrared photo cell, please adjust it as below:

There is a control code table pasted on the back of the remote controller and the transformer of the radio controller for coding.

Open the controller cover, take out the battery. There is a code pad on the PCB, the direction is from right to left, and the first code is on the right.

"0" stands for linking the middle and the top, "1" stands for linking the middle and the bottom, "X" stands for empty. The following code is: 01XX1X0X

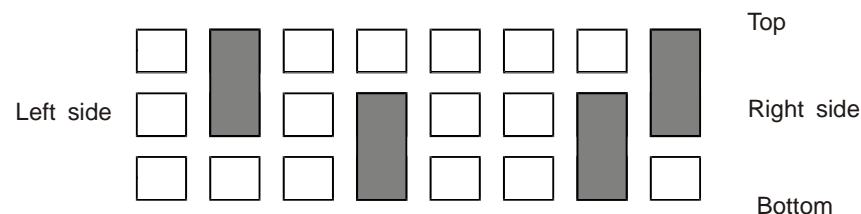

2) Installation of the infrared photocell

Photo test(Fig.13)

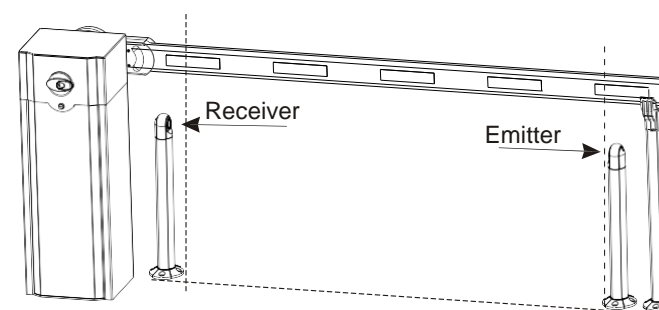
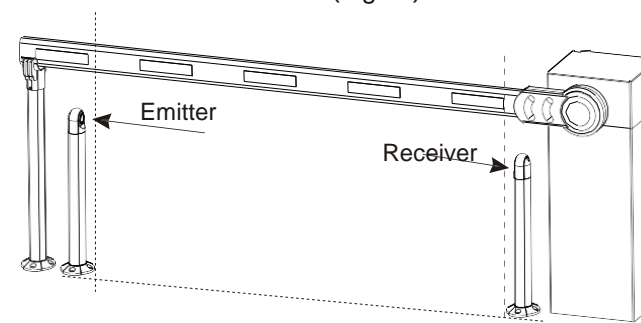

3) Adjustment of the limit switch

- (1) The blue laser obstacle on the spindle near the clutch is the laser obstacle to stop the boom after it stands straight:
When the boom is at the falling limit position, adjust this laser to make it point downwards and form an angle ($\leq 90^\circ$) with the arm.
When the laser obstacle moves into the slot and the green light is on, the rising limit will work and the boom will stand straight. Check the vertical angle between the boom and the horizontal position and adjust.

the laser obstacle, so as to make the boom be perfectly vertical.

(2) The blue laser obstacle on the spindle near the boom is the laser obstacle to stop the boom after it lies horizontally:

When the boom is at the rising limit position, adjust this laser obstacle to make it point upwards and form an angle (90°) with the arm. When the laser obstacle moves into the slot and the red light is on, the falling limit will work and the boom will lie horizontally. Check the horizontal angle between the boom and the horizontal position and adjust the laser obstacle, to make the boom be perfectly horizontal.